

Canopy Pattern: Queen/King Size

Begin with 2 pieces of **Daylite** or **Naturell** fabric. Each piece will be 13 feet long x width of the fabric (8.2 feet). Cut each fabric along the dotted lines shown on Image 1

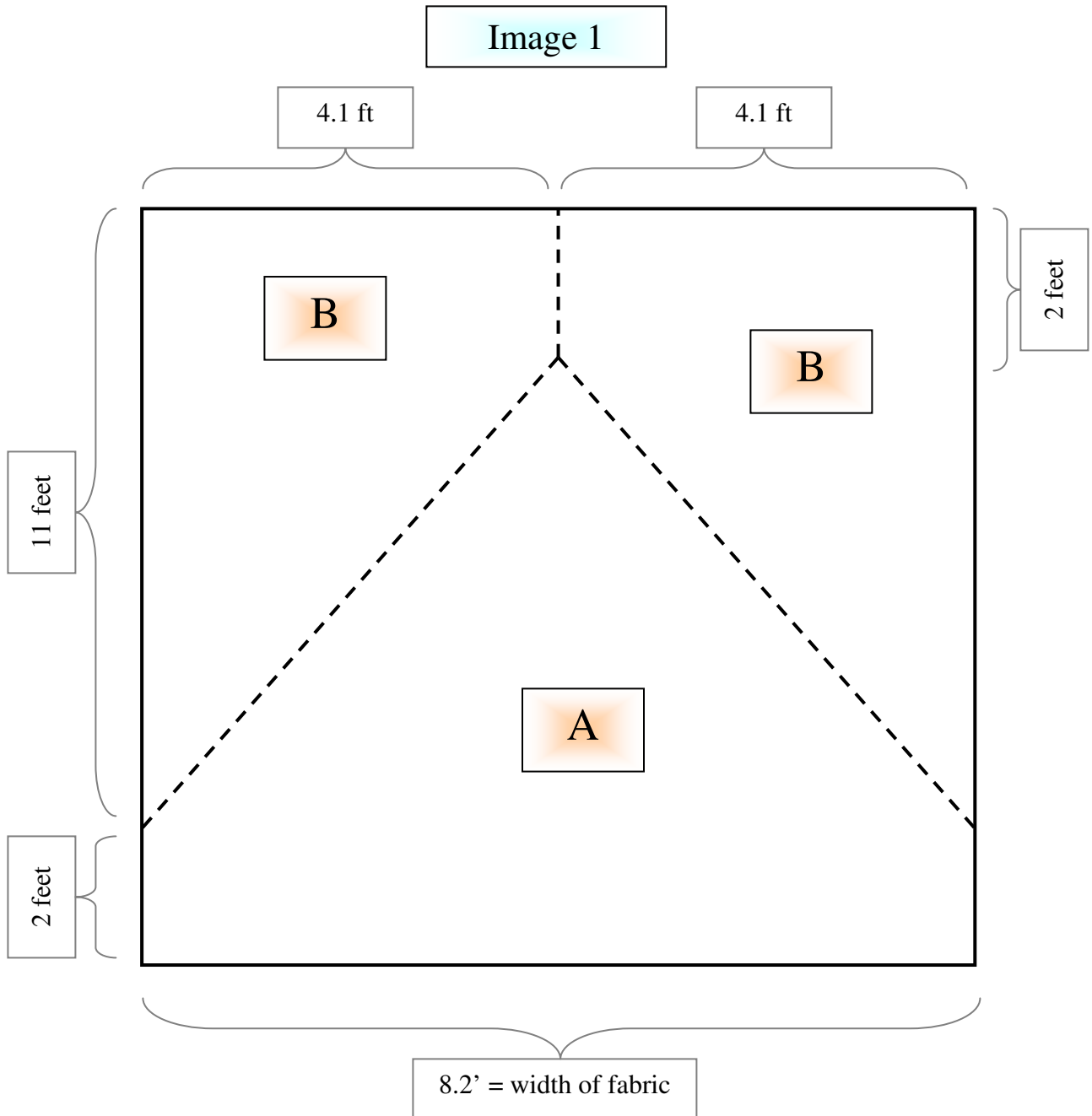

Now decide if you want slits for easy entry and exit to the bed. You can have no slits, one slit, or two slits.

For no slits, sew the two “B” pieces together on the dotted line like so:

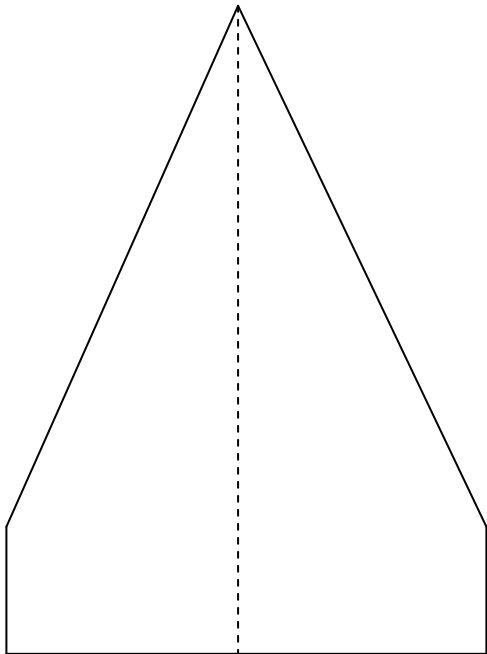

Image 2

If you want one or two slits, sew the two “B” pieces together on the dotted line like so, which allows for some overlap:

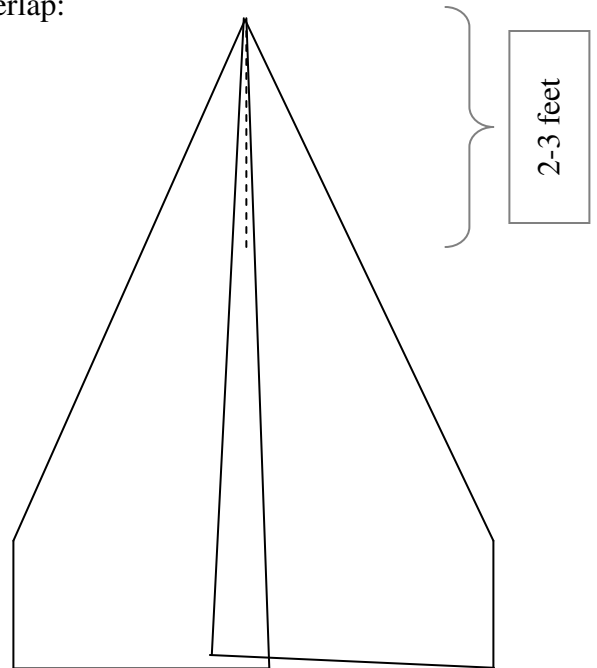
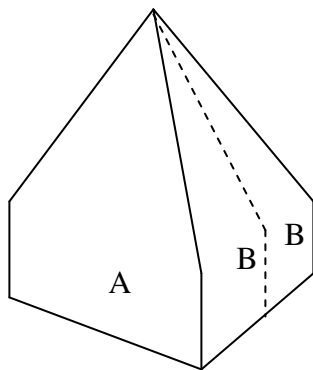

Image 3

Now sew all the large pieces together to form a pyramid type shape.



Make and attach ties to the 4 edges for connecting the hoops, about 20 inches from the top. (The exact position depends on the diameter of your hoops, measure carefully!) They can be placed on the inside or outside of the canopy.

Add a loop at the peak. A layer of reinforcement at the peak can help prevent tearing.

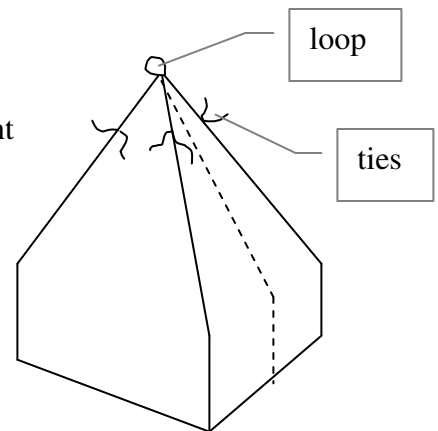

Now just tie in the hoop and hang your new canopy! You can attach the canopy loop directly to your ceiling hook, or if you have a high ceiling, use a bit of string between the hook and the canopy loop to allow the canopy to hang lower.